

## E/AL-NS 35

Order No.: 1201662



<http://eshop.phoenixcontact.de/phoenix/treeViewClick.do?UID=1201662>

End bracket, for end support of UKH 50 to UKH 240, is pushed onto DIN rail NS 35 and fixed with 2 screws, width: 10 mm, color: aluminum

### Commercial data

EAN	4017918017439
Pack	10 Pcs.
Customs tariff	85369010
Weight/Piece	0.02978 KG
Catalog page information	Page 30 (CL-2007)

### Product notes

WEEE/RoHS-compliant since:  
11/26/2005



<http://www.download.phoenixcontact.com>  
Please note that the data given here has been taken from the online catalog. For comprehensive information and data, please refer to the user documentation. The General Terms and Conditions of Use apply to Internet downloads.

### Technical data

#### General data

Height	44 mm
Length	59 mm
Width	10 mm
Material	Aluminum
Color	silver

**Accessories**

Item	Designation	Description
<b>Assembly</b>		
0801762	NS 35/ 7,5 CU UNPERF 2000MM	DIN rail, material: Copper, unperforated, height 7.5 mm, width 35 mm, length: 2 m
0801733	NS 35/ 7,5 PERF 2000MM	DIN rail, material: Steel, perforated, height 7.5 mm, width 35 mm, length: 2 m
0801681	NS 35/ 7,5 UNPERF 2000MM	DIN rail, material: Steel, unperforated, height 7.5 mm, width 35 mm, length: 2 m
1201756	NS 35/15 AL UNPERF 2000MM	DIN rail, deep-drawn, high profile, unperforated, 1.5 mm thick, material: Aluminum, height 15 mm, width 35 mm, length 2 m
1201895	NS 35/15 CU UNPERF 2000MM	DIN rail, material: Copper, unperforated, 1.5 mm thick, height 15 mm, width 35 mm, length: 2 m
1201730	NS 35/15 PERF 2000MM	DIN rail, material: Steel, perforated, height 15 mm, width 35 mm, length: 2 m
1201714	NS 35/15 UNPERF 2000MM	DIN rail, material: Steel, unperforated, height 15 mm, width 35 mm, length: 2 m
1201798	NS 35/15-2,3 UNPERF 2000MM	DIN rail, material: Steel, unperforated, 2.3 mm thick, height 15 mm, width 35 mm, length: 2 m
<b>Marking</b>		
1007248	SBS10:UNBEDRUCKT	Marker cards, unprinted, for individual labeling with the M-PEN, 250-section, perforated, white plastic
1050525	ZB10:SO/CMS	Zack strip, 10-section, divisible, special printing, marking according to customer requirements

## Drawings

### Dimensioned drawing

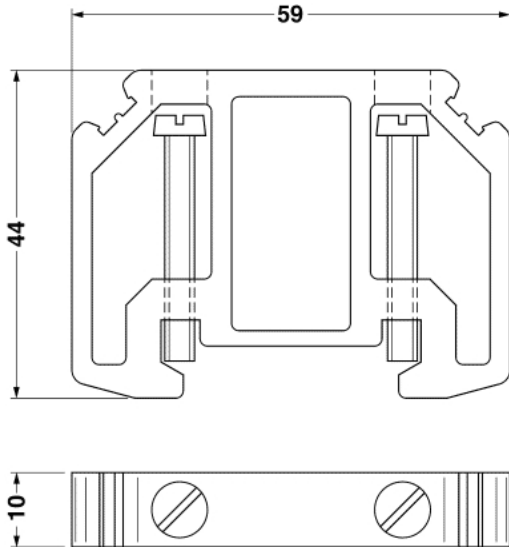

**Address**

PHOENIX CONTACT Inc., USA  
586 Fulling Mill Road  
Middletown, PA 17057, USA  
Phone (800) 888-7388  
Fax (717) 944-1625  
<http://www.phoenixcon.com>



© 2008 Phoenix Contact  
Technical modifications reserved;